

DIGITAL SIMULATION OF CLOSED LOOP ZVS-ZCS BIDIRECTIONAL DC-DC CONVERTER FOR FUEL CELL AND BATTERY APPLICATION

¹V.V. Subrahmanya Kumar Bhajana and ²S.Rama Reddy

¹Research Scholar, Bharth university, Chennai- 600073, India,

¹E-Mail: kumarbvvs@yahoo.co.in

² Professor, Jerusalem college of engineering, Chennai-600073, India

²E-Mail: srrvictory@yahoo.com

Abstract: A closed loop ZVS-ZCS bidirectional dc-dc converter is modeled and appropriate digital simulations are provided. With the ZVS-ZCS concept, the MATLAB simulation results of application to a fuel cell and battery application have been obtained whenever the input voltage exceeds the given 24V, at that time the load voltage will change from 180V to 230V. But due to this usage the load is disturbed and there is instability in the model. Using closed loop the output voltage is stabilized

Keywords: ZVS, ZCS, DC-DC, PI, TDR

1. INTRODUCTION

In recent years, the area of bidirectional DC-DC converters is improving the fuel cell economy, automobile companies are developing alternative battery operated vehicles. In addition, a major change in the electrical system of the vehicles is on the horizon by going for a 40 to 300v DC from 12/24v DC systems. The main reasons for switching over to 12v/24v to 300v are to meet the increased electrical demands of cell vehicles, to lower the current drawn from the battery, and to implement additional safety and comfort features. Also to reduce the mechanical and hydraulic components, and to improve the design flexibility of the vehicles. In hybrid/fuel cell vehicles, the main goals are to have a high efficient, small size, rugged and low cost bidirectional DC-DC converter. In hybrid/fuel cell vehicles, a power conditioning unit such as bidirectional DC-DC converter to match the fuel cell voltage with the battery pack may also required. In certain conditions, a fast response required to supply load, converter to give bidirectional power to that vehicle system with out

any disturbance. It is able to operate at adverse environmental conditions. The power semiconductor devices (MOSFET, IGBT, etc) and packaging of the individual units and the system integration play a major role in hybrid/fuel cell vehicles. The ZVS-ZCS bidirectional converter system [Bhajana, S 2009] should be efficient improve the range of performance of the battery operated vehicles. In addition to the power semiconductor devices, controllers, there are several other components such as inductors, capacitors, isolation transformer form a major portion of the ZVS-ZCS bidirectional system. To achieve the goals of the automotive environmental, several technical challenges need to develop novel techniques in switching the MOSFETS (like a zero voltage switching, zero current switching). And also to develop that system with high power density, with out switching losses need to be investigated. The soft switching converters have the advantage of lower switching losses and higher operating voltage. Hence the soft switching techniques ZVS/ZCS were needed. There is a need to develop the closed loop converter to achieve the performance of the soft switched

converter with less components and simplified control. The open loop ZVS-ZCS bidirectional DC-DC converter [Bhajana, S 2009] with two integrated function is that DC/AC and AC/DC conversion, with low losses.

This paper presents a digital simulation of closed loop ZVS-ZCS bi-directional DC-DC converter. The converter is based on a dual half-bridge topology with an auxiliary circuit in primary side and load side PI controller. It has the advantages like low EMI, low switching stresses, low switching losses compared with ZVS bidirectional DC-DC converter. The ZCS topology removes the turn-off current tail of the main switch. The ZCS operation is obtained by both forcing the primary current towards zero and delaying its raise, or by resetting the primary current before the corresponding switch turned off. The open loop and closed loop ZVS-ZCS bidirectional DC-DC converter has been simulated and developed for rectification and inversion operations in both buck and boost. The operating modes of the converter are described in the following section. The obtained results shows that the closed loop converter can be a good solution for fuel cell vehicle systems, where voltage exceeds the 24V and efficiency are key issues. Using controller feedback the closed loop system offers much more system stability. The simulations are conducted for switching frequencies of 20 KHz with 45% duty cycle.

2. POWER STAGE DESCRIPTION AND OPERATION

The ZVS-ZCS bidirectional DC-DC converter for fuel cell and battery applications [Bhajana, S 2009] is shown in Fig.1 The auxiliary circuit used in this converter and it can also used in full-bridge topologies, but this will be the scope of future work. In ZVS-ZCS bidirectional DC-DC converter the auxiliary circuit is composed of one resonant inductor L_a , one auxiliary switch S_a , and also diode D_a , so that the zero current switching (ZCS) in main switches S1 & S2 can be obtained. Switch S_a is turned on under zero current switching (ZCS) condition. When power flows from the low voltage side to high voltage side, the circuit works in ZCS condition to turned off and ZVS condition to turned on of a main switches S1, S2 in boost mode. In the other direction of power flow, the circuit operates in ZVS condition (buck mode). The transformer is used to provide isolation and voltage matching. The leakage inductance of the transformer is utilized as an interface and energy transfer element between two half-bridges. The two voltage source half-bridges each generates a square wave voltage applied to the primary and secondary of the transformer, respectively. The major draw back of this converter is TDR penalty because auxiliary circuit used in primary side. The TDR of the [2] ZVS bidirectional DC-DC converter is calculated as $TDR_P = 2V_{dc} \cdot I_{ac}$. (2 devices) = 4 P_o , where P_o is the output power. The

TDR of the ZVS-ZCS bidirectional DC-DC converter [Bhajana, S 2009] is calculated as $TDR_P = 2V_{dc} \cdot I_{ac}$. (3 devices) = 6 P_o , Where P_o is again the output power. The TDR has been increased for the ZVS-ZCS converter and the ZVS bidirectional DC-DC converter is not same output power. The main advantage of the circuit Fig.1 is the current stresses are reduced for the low voltage side main switches S1 and S2.

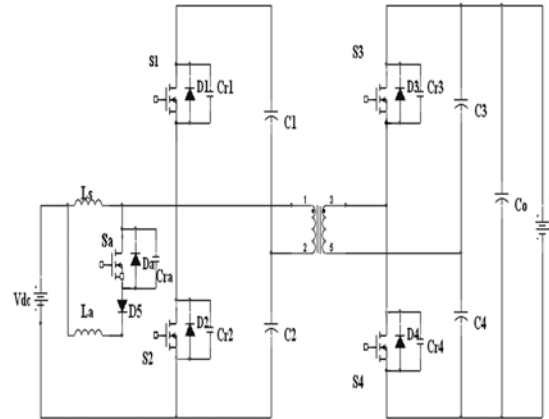

Fig.1 ZVS-ZCS bidirectional DC-DC converter

3. DESCRIPTION OF OPERATING STAGES

Fig.1 illustrates the converter topology and Fig. 2 the commutation waveforms in boost mode. ZCS is achieved by auxiliary circuit used in one half-bridge, operating the two half-bridges with a phase shift. Fig 1 is the ZVS-ZCS bidirectional dc-dc converter circuit. Fig.2 presents the voltage and current waveforms of the transformer during one switching period. In fuel cell applications, when power flows from the low voltage side to high voltage side, the circuit works in boost mode to keep the high voltage at a desired high value before fuel cell can generate power. In other direction of power flow, the circuit works in buck mode to absorb regenerated energy. Based on the idealized waveforms in fig 2, there are six operation modes in one switching cycle, and the transformer current i_r of each mode can be calculated as follows:

- (1) $i_r = (v1+v4)\theta / \omega L_s + i_r(0)$
- (2) $i_r = (v1-v3) (\theta - \phi1) / \omega L_s + i_r(\phi1)$
- (3) $i_r = 0$
- (4) $i_r = -(v2+v3) (\theta - \pi) / \omega L_s + i_r(\pi)$
- (5) $i_r = -(v2+v4) (\theta - \pi - \phi) / \omega L_s + i_r(\pi + \phi1)$
- (6) $i_r = 0$

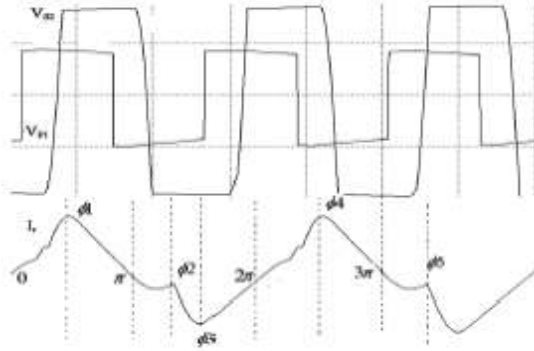

Fig. 2 Transformer voltage and current waveforms in Boost mode

The current initial conditions can be solved using the boundary conditions of

$$(7) \quad i_r(0) = i_r(\pi) = 0$$

$$(8) \quad i_r(\phi_1) = -i_r(\pi + \phi_1)$$

The output power can be regulated by phase shift angle ϕ_1 , duty cycle and switching frequency ω . If duty cycle assumed to 50% then the output power equation can be simplified as

$$(9) \quad P_o = x_o / T_s = V_{dc}^2 / \omega L_s [(\pi - \phi_3) \phi_1 / \pi]$$

Because of the asymmetry property of dual half-bridges, the operation principles of boost mode and buck mode are not the same, polarity of the phase shift angle is also.

3.1. Principle of operation

3.1.1 Boost mode: The interval of Fig.2 describes the various stages of operation during one switching period in boost mode. The converter operation is repetitive in the switching cycle. One complete cycle is divided into six steps. To aid in understanding each step, a set of corresponding annotated circuit diagrams is given in Fig. 3(a,b,c,d,e,f) with a brief description.

First stage (0 to ϕ_1): switch S_1 starts to conduct. Due to the resonant capacitor C_{r1} , the voltage across S_1 is becomes zero. During this stage C_1, C_4 are charged, C_2, C_3 are in discharged.

Second stage (ϕ_1 to π): S_1 is still turn on state. During this stage C_1, C_4 are charged, energy stored in C_2, C_3 are transferred to the load. When i_r reaches at ϕ_3 , S_a is gated to turn off S_1 . This stage finishes when S_1 is turned off.

Third stage (π to ϕ_2): at this stage S_a is turn on, remaining switches are in off state. During this stage energy stored in C_1, C_4 are transferred to the load. C_3, C_2 are in charged

Fourth stage (ϕ_2 to 2π): when S_2 is turned on, C_2 & C_3 are charged, C_3 & C_4 discharged

Fifth stage (2π to ϕ_4): At this stage S_2 is still in turn on state. During this stage C_2, C_3 are charged, energy stored in C_1, C_4 are transferred to the load

Sixth stage (3π to ϕ_5): When i_r reaches at 3π , S_a is turned on at 3π to turn-off the S_2 . At this stage S_a is turn on, remaining switches S_1 & S_2 are in off state. During this stage energy stored in C_2, C_3 are transferred to the load. C_1, C_4 are in charged This stage finishes when S_2 is turned off.

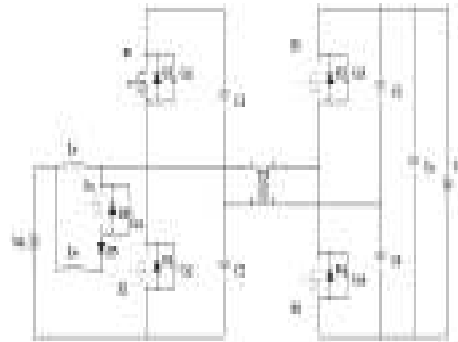

Fig.3(a) First stage

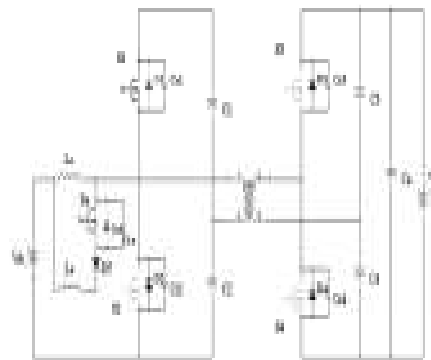

Fig.3(b). Second stage

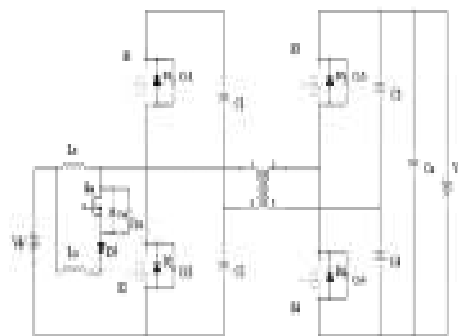

Fig.3(c). Third stage

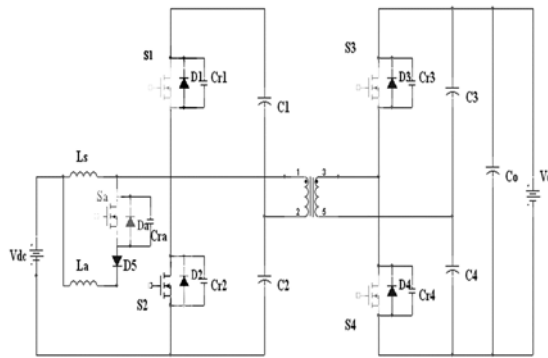

Fig.3(d). Fourth stage

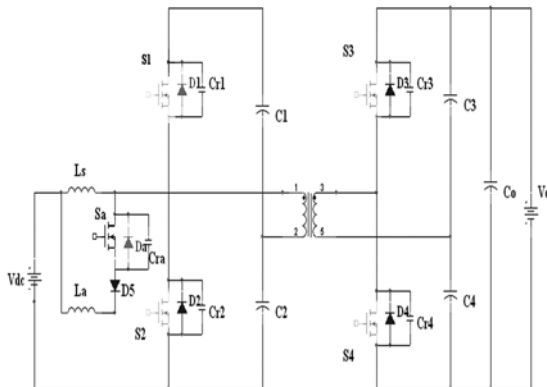

Fig.3(e). Fifth stage

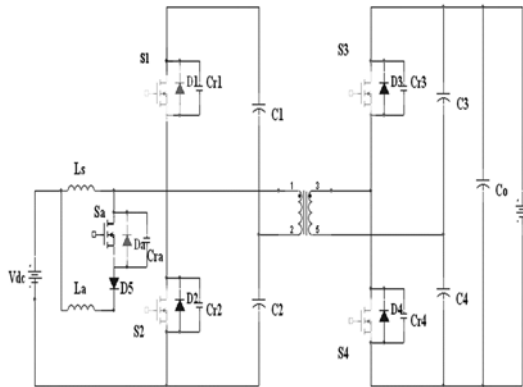

Fig.3(f). Sixth stage

3.1.2 Buck mode:

Because of the auxiliary circuit in one half-bridge the two sides are asymmetrical; the operation principles in buck mode are similar to those in boost mode except equations 3 & 6. Due to the reversed power-flow direction, the phase of the V_{S2} is leading than V_{P1} . The inductor current L_s is reversed.

The buck mode only operates under ZVS condition. This mode of operation can be divided into four steps. In this mode the switches in S_3 & S_4 are turned on and turned off at zero voltage due to the resonant capacitors C_{r3} , C_{r4} .

$$(10) i_r = (v_3 + v_2)\theta / \omega L_s + i_r(0)$$

$$(11) i_r = (v_3 - v_1)(\theta - \phi_1) / \omega L_s + i_r(\phi_1)$$

$$(12) i_r = -(v_3 + v_2)(\theta - \pi) / \omega L_s + i_r(\pi)$$

$$(14) i_r = -(v_4 + v_2)(\theta - \pi - \phi) / \omega L_s + i_r(\pi + \phi)$$

4. CLOSED LOOP ZVS-ZCS BIDIRECTIONAL DC-DC CONVERTER

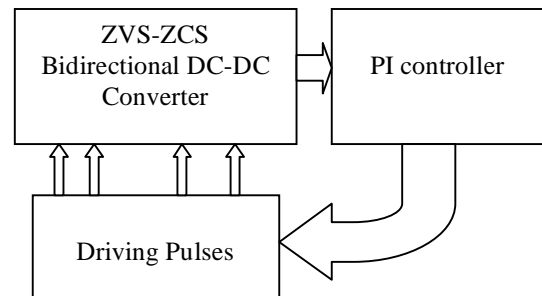

Fig.4. Closed loop ZVS-ZCS bidirectional DC-DC converter

Fig.4. show that closed loop ZVS-ZCS bidirectional DC-DC converter consists a PI (proportional integral) controller at load side so that whenever input supply is increased or decreased, the load voltage will be disturbed so as to prevent switching losses and to keep constant load voltage. In case of load voltage disturbance the PI controller will transmit error voltages which inturn will subsequently control the pulse widths of MOSFETs. This closed loop controller can act as PWM controller also. In this paper such a controller has been developed which maintains constant load voltage. The digital simulation is achieved with the help of Matlab- Simulink software. Due to sudden transit disturbances in supply voltages, the load voltage will change from one level to other, thus facilitating enhanced system stability.

Discrete controller Parameters used in simulation are $K_p = 170$, $K_i = 15$. These parameters used to tuning of PI controller. Fig.5 shows that PI controller used to control the load voltage in source disturbance condition. In source disturbance condition the PI controller respond after 9.1msec and the load voltage kept in desired level. In this paper the load voltage disturbed in from 180V to 230V (source disturbed condition) without PI controller, by using PI controller the load voltage is stable state at 180V.

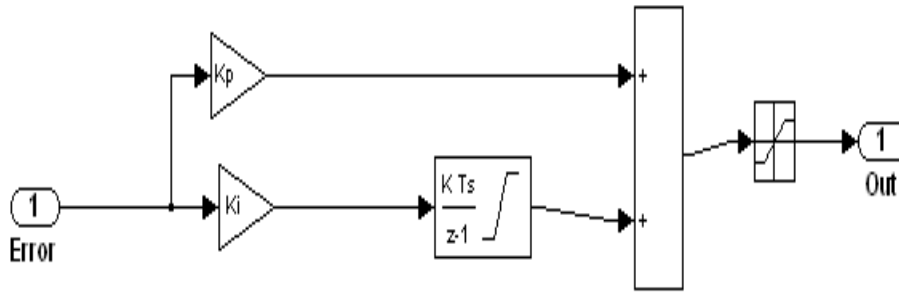

Fig. 5 PI controller used in simulation

5. SIMULATION EVALUATION OF THE CLOSED LOOP ZVS-ZCS BIDIRECTIONAL CONVERTER

5.1 Simulation results

The detailed closed loop ZVS-ZCS bidirectional circuit model is built using Matlab/Simulink. The simulated results are compared with open loop ZVS-ZCS bidirectional DC-DC converter to show the performance of the converter.

5.1.1 Boost mode: The following parameters are selected according to a 175W for fuel cell and battery applications. $V_b = 24V$, $R_b = 1\Omega$, $D = 45\%$, $f_s = 20$ kHz, $L_s = 380 \mu H$, $L_a = 4.96 \mu H$, $C_{p1} = C_{s1} = 20mF$, $C_0 = 150mF$, $R_L = 0.5\Omega$. Simulations of the closed loop ZVS-ZCS bidirectional converter waveforms are presented in Fig. 6(a,b,c). shown are the PI controller response under source disturbance condition, open loop output voltage under disturbance condition, closed loop output voltage under source disturbance condition, and primary side switching voltage, primary side transformer current, output voltage. The simulations conducted when there is supply voltage disturbed at 9.1msec then the PI controller stabilizes the load voltage after 0.01 secs, the primary side switches operate under ZVS, ZCS conditions.



Fig.6 (a) PI controller response under source disturbance condition at 9.1msec

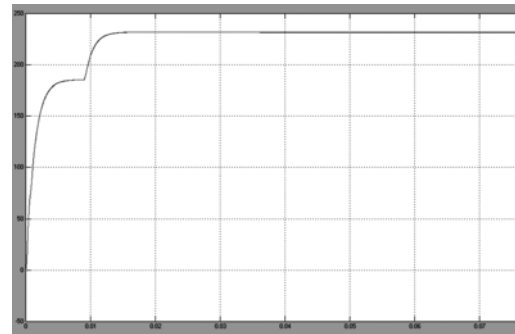

Fig. 6(b) Open loop output voltage under source disturbance condition at 9.1msec

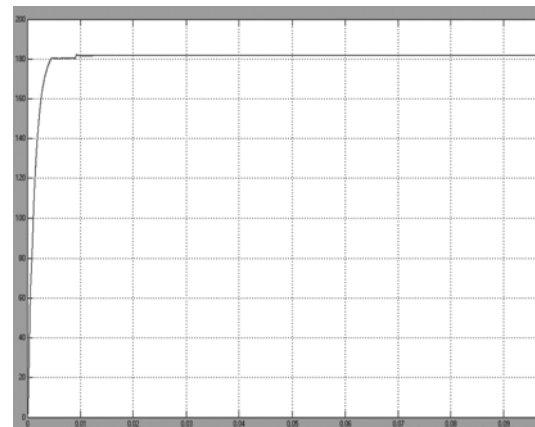

Fig.6(c) Closed loop output voltage under source disturbance condition

5.1.2 Buck mode: Similarly, the buck mode can also be simulated using same parameters as boost mode. Simulations of the closed loop ZVS-ZCS bidirectional converter waveforms are presented in Fig. 7. shown are the primary side switching voltage, primary side transformer current, output voltage. The

simulations revealed modes of operation where the primary side switches operate under ZVS condition.

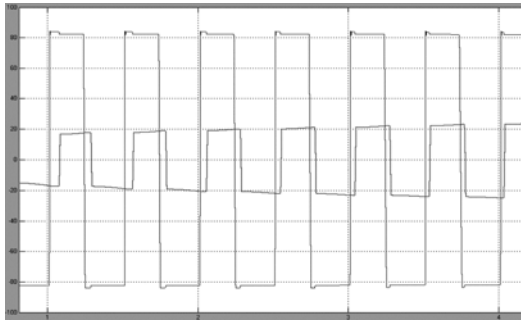

Fig. 7 Transformer voltages primary and secondary side voltages in buck mode

TABLE - I
SIMULATION PARAMETERS

Parameter	Description
Input voltage	$V_i = 24V$
Load voltage	$V_o = 180V$
Output power	$P_o = 175W$
Boost inductor	$L_o = 380mH$
Resonant inductor	$L_I = 4.9mH$
Resonant capacitor	$C_{r1} = 3.3nF$
Resonant capacitor	$C_{r2} = 3.3nF$
Input capacitors	$C_1 \& C_2 = 20\mu F$
Output capacitors	$C_3 \& C_4 = 20\mu F$

6. CONCLUSION

A digital simulation of closed loop ZVS-ZCS bidirectional DC-DC converter has been presented in this paper. The operation, and simulation results were illustrated. Simulation results for the 175W and 20 kHz model were shown to verify the operation principle. It is shown that ZVS-ZCS in one direction of power flow is achieved in boost mode with no switching losses involved and other direction of power flow involves ZVS with no switching losses. Due to the simultaneous boost conversion and inversion provided by the low voltage side half bridge, current stresses on the switching devices and transformer are reduced by switching an auxiliary switch in primary side i.e. ZCS condition. As results, advantages of the new circuit including ZVS-ZCS with full load range, current stresses are reduced, high efficiency. The major drawbacks of this converter is cost is increment due to the auxiliary circuit components, controller and decreased output power. This converter for medium power applications like fuel cell and battery, with high power density. Excellent dynamic performance is obtained because the auxiliary circuit used in one of half bridge. The use of PI controller in implementing the feed back closed loop system for the stabilizes the

system and the load is kept intact, lowering further switching losses.

REFERENCES

- D.Makasimovic, S.Cuk (1991). A general approach to synthesis and analysis of quasi-resonant converters," *IEEE Trans.Power Electron.*, vol. 6, No. 1,Jan 1991. pp 127-140
- Fang Z.Peng,Hui Li,Gui-Jia,Jack S.Lawler (2004). A new ZVS bidirectional dc/dc converters for fuel cell and battery application. In: *IEEE Transactions on Power Electronics*, Vol. 19,No. 1, pp 54-65.
- Fang Z.Peng,Hui Li (2004). Modeling of a new ZVS bidirectional dc-dc converter, In: *IEEE Transactions on Power Electronics*, Vol. 40, No. 1, Jan 2004, pp 272-283
- F.Carichhi, F.Crescimbin, F.G.Capponi, and L.Solero (1998). Study of bidirectional buck-boost converter topologies for application in electrical vehicle motor drives. In: *Proceedings of IEEE Applied Power Electronics Specialists Conf. Expo*, pp. 287-293
- H.L.Chan, K.Cheng, and D.Sutanto, (2000). An extended load range ZCS-ZVS bidirectional phase shift dc-dc converter. In: *Proceedings of 8th International conference Power Electronics Variable speed drives*, pp 74-79.
- H.Chung et al. (2004). A ZCS bidirectional flyback dc-dc converter. *IEEE Transactions on Power Electronics*, Vol. 19,No. 6, pp 1426-1434.
- L.C.Freitas, D. F. Cruz, and V.J. Farias, (1993). A novel ZCS-ZVS PWM dc-dc converter for high switching frequency: analysis,simulation and experimental results. In: *Proceedings of IEEE APEC*, San Diego, pp 693-699
- Manu Jain, M.Daniele, and Praveen K.Jain, (2000). A bidirectional dc-dc converter topology for low power application. In: *IEEE Transaction on Power Electronics*,Vol. 15, No.4,pp 595-606
- R. L. Lin, Fred C.Lee, (1996). Novel zero-current switching-zero-voltage switching converters. In: *proc. IEEE PESC'96*, pp. 438-442.
- R. W. DeDonker, D. M. Divan, and M.H.Kheraluwala (1991). A Three-phase soft-switched high power density dc-dc converter for high power applications. In: *IEEE Trans. Ind.Applicat.*, vol. 27, pp.. 63-73.
- R. Mendes Finzi Neto,F.Lessa Tofoli, and Luis Carlos de Freitas (2005). A High power-factor half-bridge doubler boost converter without commutation losses. In: *IEEE Trans.Power Electron*, vol. 52, No. 5, pp 1278-1285.
- S. Hamada et al. (2002). A novel zero-voltage and zero-current switching PWM dc-dc converter with reduced conduction losses. In: *IEEE Trans. Power electron.*, vol. 17, pp. 413-419.
- V.V.Subrahmanya kumar Bhajana, S.Rama Reddy (2009). A novel ZVS-ZCS bidirectional DC-DC converter for fuel cell and battery application" in *proc. IEEE PEDS'2009*



V.V.SUBRAHMANYA KUMAR BHAJANA received his B.E. degree in Electronics and Communication Engineering from Sapthagiri College of Engineering, Dharmapuri, Tamilnadu, India (University Of Madras), in 2000 and there after, he did his M.E degree in Power Electronics and Drives from

the P.S.N.A College of engineering and Technology, Dindigul, Tamilnadu, India under Anna University, Chennai in the year 2005. He is presently a research scholar at Bharath University Chennai, India. His key area of interest is Power Electronics engineering, which includes soft switching DC - DC converters and their applications.



S.RAMA REDDY is professor of electrical department, Jerusalem engineering college, Chennai, Tamilnadu, India. He obtained his L.E.E. from S.M.V.M.ploytechnic, Tanuku, A.P, A.M.I.E. in electrical engineering from institution of engineers (India), and M.E. in Power

Systems from Anna University. He has published over 20 technical papers in national and international conference proceedings/journals. He has secured A.M.I.E. institution gold medal for obtaining highest marks. He has secured AIMO best project award and Vijaya Ratna Award. He has worked in Tata Consulting Engineers, Bangalore and Anna University, Chennai. He has teaching experience of 12 years. His research interest is in the areas of resonant converters, VLSI, and solid state drives. He is life member of institution of engineers (India), Indian society for technical education, system society of India and society of power engineers. He is a fellow of institution of Electronics and Telecommunication engineers (India). He has published text books on power electronics and solid state circuits.