

## COMPUTER SIMULATION OF PHASE SHIFTED SERIES RESONANT DC TO DC CONVERTER

P.Parvathy<sup>1</sup>, Dr. N. Devarajan<sup>2</sup>

<sup>1</sup>Research scholar, Anna University Coimbatore.

<sup>2</sup>Associate Professor of Electrical Eng, Government College of Technology, Coimbatore.

Email: parvathyvijayakumar@yahoo.com

**Abstract:** This paper deals with digital simulation of phase shifted series resonant DC to DC converter using Matlab Simulink. The Simulink models for open loop and closed loop systems are developed and they are used for simulation studies. This converter is capable of producing ripple free DC output. Switching losses and switching stresses are reduced by using soft switching. This converter has advantages like high power density and low switching losses. Theoretical predictions are well supported by the simulation results.

**Keywords:** Phase - shifted series resonant converter, quasi current mode control, soft switching

### 1. INTRODUCTION

H-BRIDGE system used in high power DC-DC conversion is a popular and well-received method in many applications (Sable, and Lee, 1989; Forsyth, et al., 1991a, b; Chan et al., 2001)]. The basic H- bridge converter can be modified easily by introducing soft-switching to the converters. There are many types of soft-switching converters including load resonant (Steigerwald, 1988), square-wave resonant (Forsyth, et al., 1991a), and zero-voltage and zero current resonant (Chan et al., 2001). The phase-shifted series resonant converter (PSRC) based on an H- bridge has the advantage of inherent short circuit protection characteristic and high conversion efficiency. Unbalanced switching signal will not cause saturation to the transformer due to presence of the series resonant capacitor. Fig.1 shows the schematic diagram of the PSRC. The two switching devices ( $S_1$  and  $S_3$ ,  $S_2$  and  $S_4$ ) in each leg of the H-bridge are

switched alternatively with almost 50% duty ratio. The switching pulses to the two legs have a phase angle of  $\alpha$  in order to change the voltage applied to the resonant tank as shown in Fig.2. The general design rule is that the switching frequency  $f_s$  of PSRC is always chosen to be close to the resonant frequency  $f_r$ , defined by the resonant inductor  $L_r$  and resonant capacitor  $C_r$  to make the resonant current waveform be quite sinusoidal (Steigerwald, 1988). Of course, to reduce the size of energy storage components such as inductor, capacitor and transformer, the switching frequency  $f_s$  is very high. The resonant current  $i_r$  is regulated by changing the phase angle  $\alpha$  and rectified as the input power single of the output filter. Thus the output voltage is controlled. Normally the value of the load resistance and the input DC voltage are variable within a specific range, the voltage feedback and certain closed-loop control law should be employed to keep the output voltage at the desired values. Though the

error can be eliminated through the algorithm of the controller, the dynamic performance may not be satisfied especially for nonlinear systems. Other publication on load range extension using ZCS and ZVS (Chan et al., 2003) and PWM with phase shift (Xu et al., 2004) are the primary control for the switching signal. Some more advanced control strategies were developed recently to improve the performance of control system (Sira-Ramirez, et al., 1998; Han, et al., 2002; Jacobson, et al., 1995), but they depend on the accuracy of the plant model or much more complicated computation is required. The control methods in the past have been reported in using the adaptive control such as auto-disturbance-rejection control (ADRC) (Lu, et al., 2006) and passivity-based control (Lu, et al., 2005). A novel control system for the PSRC is proposed in this paper. By regulating the resonant current which is rectified for supplying the load, the dynamic control performance of the converter system is improved as compared with that of the conventional PSRC control system. The ability against load disturbance is close to that of the system employing ADRC though structure of the reformed system is simpler and only voltage feedback is required. The proposed method is called quasi-current mode because the current controlled is regulated indirectly using the resonant tank voltage vector. The method is similar to the d and q current control for multilevel converter (Soto-Sanchez, and Green, 2001) but the present method is based on the control using resonant component phasor. The literature (Sable, and Lee, 1989; Forsyth, et al., 1991a,b; Chan et al., 2001; Chan et al., 2003; Steigerwald, 1988; Xu et al., 2004; Sira-Ramirez, et al., 1998; Han, et al., 2002; Jacobson, et al., 1995; Lu, et al., 2006; Lu, et al., 2006; Soto-Sanchez, and Green, 2001) does not deal with the simulation of closed loop controlled phase shifted series resonant converter. In the present work, a closed loop circuit model is developed and it is used for simulation studies.

## 2. ANALYSIS OF THE PHASE-SHIFTED SERIES RESONANT CONVERTER

The main circuit of the PSRC and its waveforms are shown in Figs. 1 and 2, respectively. The resonant circuit is fed by a quasi-square voltage signal  $v_i$  in which the width of  $\alpha$  is adjustable. The frequency of the voltage  $v_i$  generated by the H-bridge is the switching frequency  $f_s$ . The waveform of the primary voltage  $v_p$  of the transformer is square which has the same polarity as the resonant current  $i_r$  because  $v_p$  is actually the direct reflection of the output voltage through diode bridge and transformer. The resonant tank is characterized by its resonant frequency denoted by  $f_r = 1/(2\pi\sqrt{L_r C_r})$ . If the switching frequency  $f_s$  is chosen to be close to the resonant frequency, then the resonant current is quite sinusoidal. In this case, using fundamental waveform

for approximation is reasonable for analyzing the resonant circuit [8]. Now then  $v_i$  and  $v_p$  are taken as fundamental component for the following analysis of the resonant tank at steady-states. Using Fourier analysis, the amplitude of  $v_i$  is

$$(1) \quad V_i = \frac{2}{\pi}(1 - \cos \alpha)E$$

where  $E$  is the input dc voltage and the amplitude of  $v_p$  is

$$(2) \quad V_p = kV \frac{4}{\pi}$$

where  $k = N_p / N_s$  and  $V$  is the output voltage. The voltage balance equation of the resonant circuit can be expressed as:

$$(3) \quad \vec{V}_i = \vec{V}_p + \Delta \vec{V}_x$$

$$(4) \quad \Delta \vec{V}_x = \vec{V}_{Lr} + \vec{V}_{Cr}$$

$$(5) \quad \Delta V_x = I_m(X_L - X_C)$$

where  $X_L = \omega_s L_r$ ,  $X_C = 1/\omega_s C_r$ ,  $\omega_s = 2\pi f_s$  and  $I_m$  is the peak value of  $i_r$ .

The voltage across the primary side of the transformer has the same phase as the resonant current, hence the voltage phasor diagram of the resonant tank is shown as Fig.3 and (6) is true

$$(6) \quad V_i = \sqrt{(\Delta V_x)^2 + (V_p)^2}$$

The function  $F(V_i)$  can be obtained using (1)

$$(7) \quad \alpha = F(V_i) = \cos^{-1} \left( 1 - \frac{\pi V_i}{2E} \right)$$

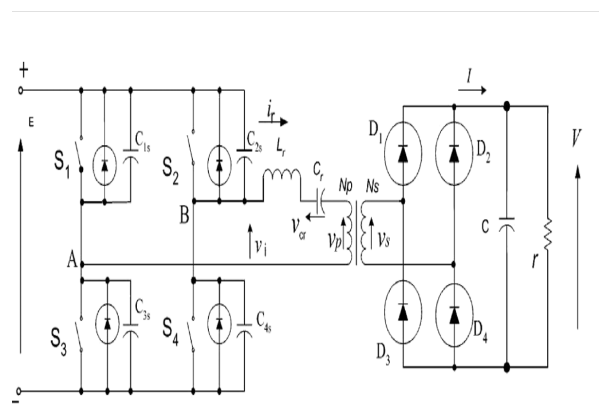

Fig.1. Circuit of the PSRC

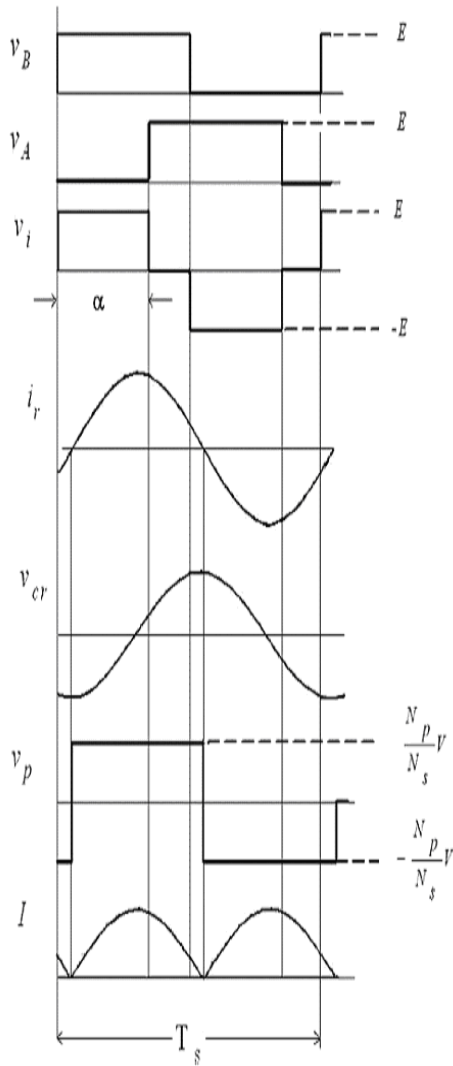

Fig.2. Waveforms of PSRC

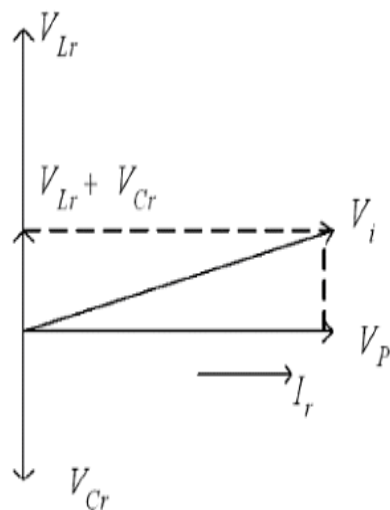

Fig.3. Phasor diagram of resonant tank

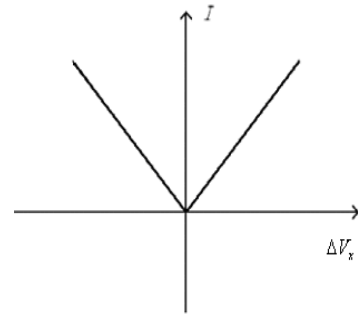

Fig.4. Current  $I$  against the voltage  $\Delta V_x$

### 3. SIMULATION RESULTS

Digital simulation is done using Matlab and the results are presented here. Open loop system is shown in Fig.5. Input voltage with a step disturbance is shown in Fig.6. The output voltage in open loop system is shown in Fig.7. The output voltage increases with the increase in the input voltage.

The Simulink model of closed loop system is shown in Fig.8. Output voltage is sensed and it is compared with the reference voltage. The error is processed through a PI controller. A controlled rectifier is recommended at the output to regulate the output voltage. When the output voltage increases, the error increases and the pulse width applied to the MOSFETs of the rectifier decreases to maintain the output voltage constant. Input voltage with step disturbance is shown in Fig.9. There is a step rise in the input. The response of closed loop system is shown in Fig.10. The output voltage reduces to the steady state value. Thus the steady state error is reduced by using closed loop system.

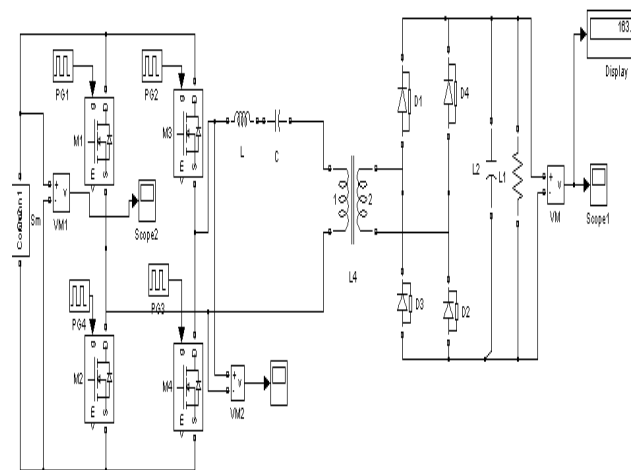

Fig.5. Open Loop Controlled DC to DC Converter

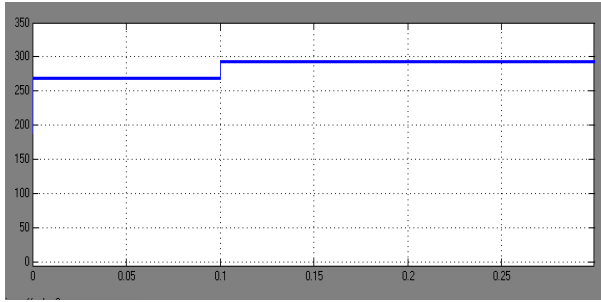

Fig.6. Input Voltage with Disturbance

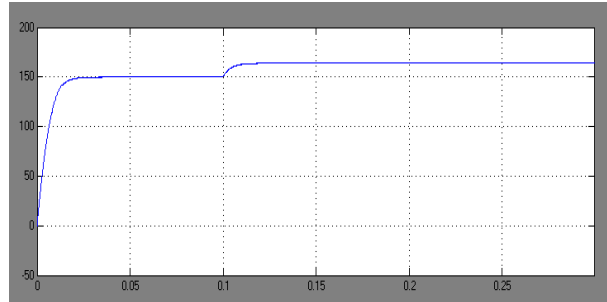

Fig.7. Output Dc Voltage with Disturbance

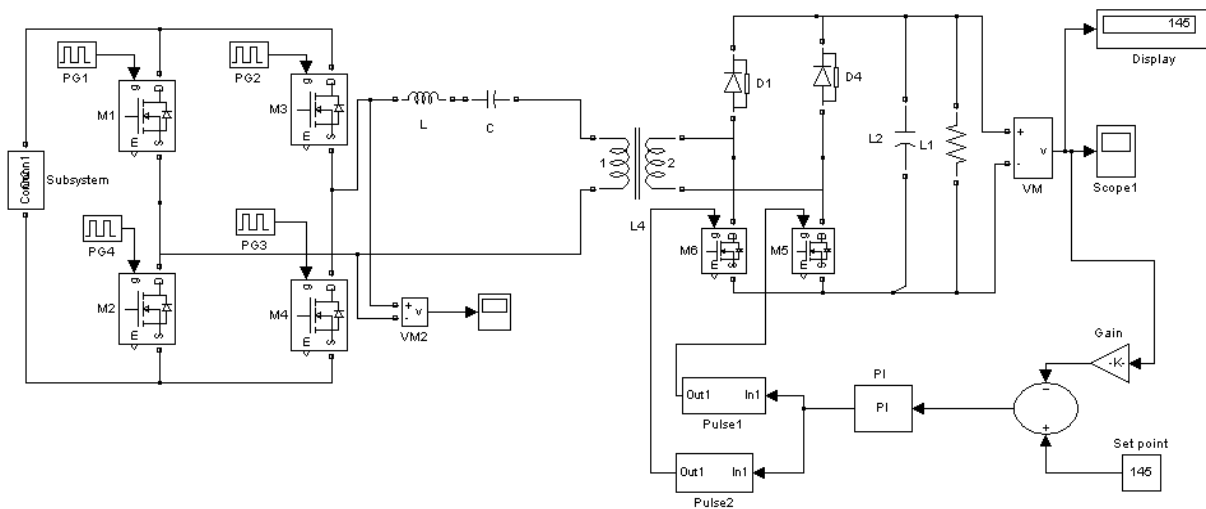

Fig.8. Closed Loop Circuit Mode

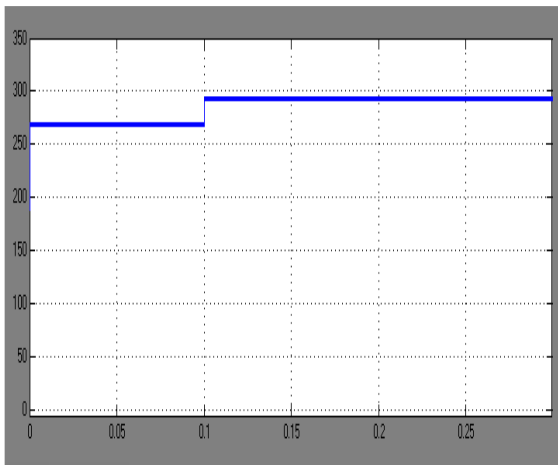

Fig.9. Input Voltage with Disturbance

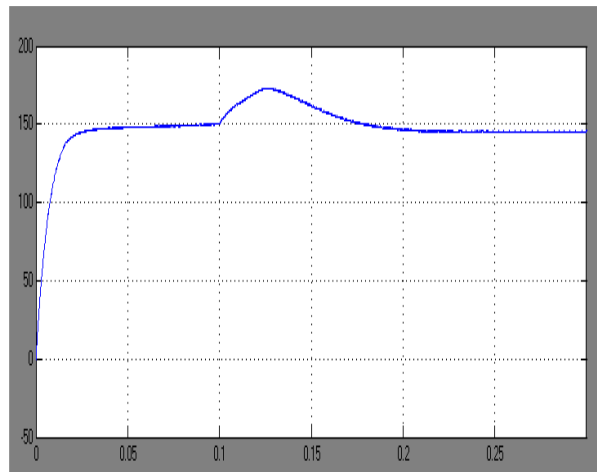

Fig.10. Output Voltage with Disturbance

#### 4. CONCLUSION

Phase shifted series resonant converter is designed and simulated in open loop and closed loop. The simulink models for open loop and closed loop systems are presented. The closed loop system is capable of maintaining constant output voltage by using a controlled rectifier at the output. The phase shifted resonant DC to DC converter has advantages like smaller L & C, reduced switching stresses and higher efficiency. The simulation results coincide with the theoretical predictions. This converter can be used for battery charging, electrolysis and speed control of servo drives. The present work recommends a synchronous rectifier at the output to maintain the output constant.

#### 5. REFERENCES

- Chan .H. L., Cheng. K. W. E and Sutanto. D. (2001), "Phase-shift controlled DC – DC converter With bi-directional power flow," *Proc Inst. Elect.Eng.*, **vol. 148**, no. 2,pp.193- 201.
- Chan .H.L., Cheng, K.W. E and. Sutanto D,( 2003) "A ZCS-ZVS Bi-directional phase shifted DC – DC converter with extended load range," *Proc. Inst. Elect. Eng.*, **vol. 150**, no.3, pp 269 – 277.
- Forsyth A. J., Evans P. D., .Al- Mothafar . M. R. D and. Cheng . K. W. E (1991)"A comparison of phase shift controlled resonant and square-wave converters for high power ion engine control" in *Proc. Eur. Space Power Conf.*, pp.179-185.
- Forsyth .A. J, Evans P. D., Cheng. K. W. E, and Sutanto. D,and Al- Mothafar, M.R.D (1991)" Operating limits of power converters for high power ion engine control," in *Proc. 22<sup>nd</sup> Int .Elect.Propul.Conf.*,[CDROM].
- Han. J.Q, " From PID to auto-disturbance- rejection control ," *Trans. Control Eng. China*, **vol. 9** no. 3, pp. 13 – 18,May 2002.
- Jacobson .C. A, Stankovic. A. M., and Tadmor. G., (1995)" Design of robust controllers for resonant DC/DC converters, " in *Proc. 4<sup>th</sup> IEEE Conf – Control Appl.*, , pp . 360 – 365.
- Lu Y, Cheng K. W. E., Ho. S. L., and Pan J. F, (2005), "passivity - based control of phase shifted resonant converter," *Proc. Inst. Elect. Eng.* **vol. 152**, no.6, pp. 1509-1515.
- Lu .Y, Cheng. K. W. E., and. Ho. S. L., (2006) "Auto-disturbance-rejection control for the phase shifted resonant converter," *Proc. Inst. Elect.Eng.*, **vol. 153**. no.5,pp.711 – 718, .
- Sable .D. M, and Lee F.C, (1989) "The operation of A full bridge, zero-voltage switched PWM converter" in *Proc. Virginia Power Electronic .Ctr Sem* , pp. 92-97.
- Sira-Ramirez. H., R. Ortega, and M. Garcia-Esteban, (1998) " Adaptive passivity-based control of average dc-to-dc power converter models, " *Int. J.Adaptive Contr. Signal Process.*, **vol. 12**, pp.63-80.
- Soto-Sanchez.D.E.and T. C. Green(2001) ," Voltage balance and control in a multilevel unified power flow controller ," *IEEE trans. Power Delivery*, **vol.16**. no.4, pp.732 –738. .
- Steigerwald.R.L.,(1988) " A comparison of half-bridge resonant converter topologies, " *IEEE Trans. Power Electron.*,**vol. PE-3**, no. 2, pp. 174 – 182.
- Xu.D.H, Zhao.C. H, and. Fan H. F, (2004.)" A PWM plus phase-shift control bidirectional dc-dc converter, " *IEEE Trans. Power Electron.*, **vol. 19**, no. 3, pp.666 – 675.