

ON THE SNUBBER INFLUENCE TO THE SWITCHING AND CONDUCTION LOSSES IN A CONVERTER USING SWITCHED CAPACITOR

Stelian JUDELE, Razvan SOLEA, Viorel DUGAN

„Dunarea de Jos” University of Galati, 47 Domneasca Street, 6200 Galati, tel/fax:
036-460182 e-mail: stelian.judele@ugal.ro, razvan.solea@ugal.ro,
viorel.dugan@ugal.ro

Abstract: The paper deals to design and to compute the snubber parameters influence on the switching and conduction losses of the transistors (IGBT) used as bidirectional switches in a converter with switched capacitor. The converter was modelled with difference equations, and the transistors during turn-on and turn-off processes were simulated by dynamically varying resistance models. The energy loss per switching, commutation time, the variation of the transistor voltage etc. and the influence of snubber parameters in each of these cases are shown in the context of a converter used as a 50Hz reactive power controller unit.

Keywords: Switched capacitor converter, Bidirectional switches with IGBT, dynamically varying resistance models, Snubbers, Commutation and conduction losses.

1. INTRODUCTION

The basic principles of active filters were proposed in the beginning of the 1970's (Sasaki et al., 1971). The advance of power electronic technology over the last two decades, and because active filters have been studied by many researchers, engineers and PhD students, has been made it possible to put active filters into practical applications for harmonic compensation, flicker compensation and voltage regulation. In present, these above three applications of shunt (especially) active filters have been put on a commercial base in Japan, and their rating or capacity has ranged from 50 KVA to 50 MVA (Akagi, 1995). Step-by-step, very probable, the function of active filters will be expanded in future from harmonic compensation, voltage flicker compensation or voltage regulation into power quality improvement for power distribution systems as the capacity of active filters becomes larger. It is possible, perhaps, as the differences between the Flexible AC Transmission Systems (FACTS) devices and active filters and/or active power line conditioners to vanished in future, and a new family,

with a generic name of power quality conditioners, will appear. Among the lots of active filters as configurations (shunt, series, hybrid active and passive, voltage-/current-fed PWM inverter as power circuit, frequency -/or time-domain as control strategies etc.), the circuit analysed here from the point of view of the switching and conduction loss when operating as an active filter, was firstly mentioned in (Chakravorti, 1992).

2. MATHEMATICAL MODEL OF THE CONVERTOR WITH SWITCHED CAPACITOR (CSC)

The elementary switched capacitor circuit and the four conduction states (nodes) are show in Figure1 and Table 1 (Judele, 2001). The converter is operated in such manner that only one of the switches from each of the upper (superior) and the lower (inferior) parts of the converter bridge is conducting at a time. The conduction transient in each of the conduction modes is computed by modelling the differential equations with the below difference equations. (Judele, 2001)

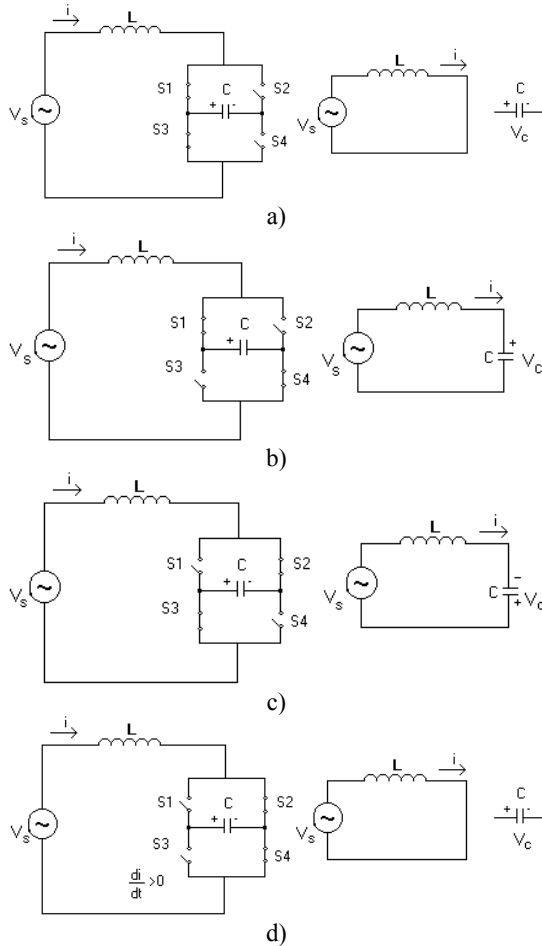

Fig. 1. The four conduction states and the equivalent circuits; a, b, c, d = modes 1,2,3,4 respectively

For the modes 1 and 4 (n is the discrete time step index) we have:

$$i(n) = \frac{\Delta T}{L} v_s + i(n-1) \quad (1)$$

$$v_c(n) = v_c(n-1) \quad (2)$$

and for the modes 2 and 3:

Table 1. Conduction states (modes) of the CSC

Mode No.	Switches			
	S1	S2	S3	S4
1	closed ($v_s > 0$)		conducting when $di/dt > 0$	
2	closed ($v_s > 0$)			Conducting when $di/dt < 0$
3		closed ($v_s < 0$)	conducting when $di/dt < 0$	
4		closed ($v_s < 0$)		Conducting when $di/dt < 0$

$$(3) \quad i(n) = \frac{v_s - k \cdot v_c(n-1) + \frac{L}{\Delta T} i(n-1)}{\frac{L}{\Delta T} + \frac{\Delta T}{L}}$$

$$(4) \quad v_c(n) = \frac{\Delta T}{C} i(n) + v_c(n-1)$$

where $k=1$, if $v_s > 0$, i.e. mode 2, and $k=-1$, if $v_s < 0$, i.e. mode 3.

These difference equations for this converter can be used in researching of the steady state and dynamic responses, for the determination of the active filter limitations (Judele, S. et al, 2001), but and for the snubbers design, and for the switching and conduction loss computation.

3. SNUBBER CIRCUITS

To implementation of this converter (Figure 2) can be used or transistors BJT, or IGBT or MOSFET, with some specific differences between the mentioned solutions.

Using copackaged IGBTs (IGBT + ultra - soft recovery diode in the same package) in a series configuration (emitter to emitter), the problem of violating the conductivity modulation is solved. For each half of the AC waveform, one IGBT (or BJT or MOSFET) and the opposite diode is in conduction being an AC switch, Figure 2.

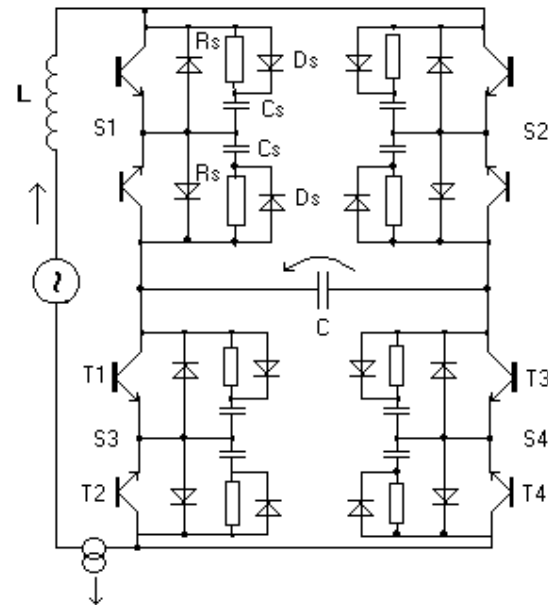

Fig. 2. The converter circuit with switched capacitor and turn-off snubbers for the transistors.

As with most of the other applications where snubbers are used to protect and to reduce the electrical stresses of the transistors and the switching losses, turn-off snubbers are used in this converter functioning as an active filter.

A snubber circuit reduces the switching stresses to safe levels (within the limits of the "reverse bias safe operating area = RBSOA") by: i) limiting or provide a zero voltage across the transistor while the current turns off (*turn - off snubbers*); ii) limiting device

currents, the rate of rise (di/dt) of currents through device, to reduce switching losses at high switching frequency and for limiting the maximum diode reverse recovery current at device turn-on (*turn-on snubbers*); iii) limiting the rate of rise (dv/dt) of voltage across devices during device turn-off due to stray inductances (*overvoltage snubbers*).

From a circuit topology perspective, there are three basic types of snubbers: i) unpolarized C or series R-C snubbers; ii) polarized R-C snubbers (charge-discharge RCD and charge-restraint/suppressing RCD) and iii) polarized L-R snubbers (Mohan 1995, IRC 1994).

Figure 2 shows the converter circuit with turn-off snubbers (charge-discharge RCD) used for the transistors.

An appropriate choice of the snubber elements of this converter (Ds, Rs and Cs) may help to reduce the switching losses considerable. During the process of commutation, one of the transistors of the lower half of the converter bridge (S3 or S4, Figure 2) is turning-off while the other is turning-on. The commutation transients are, therefore, affected by the turn-on and turn-off characteristics of the transistors, the snubber elements and the values of the inductor current *i* and the capacitor voltage *v_c*. Because the duration of commutation interval (2 - 3μs) is small compared to the conduction time of each switch (approximately 20μs corresponding to 25kHz), the inductor current and the capacitor voltage can be considered as constant current and voltage sources, respectively, in this interval.

The transistors during turn-on and turn-off processes were modelled by effective time varying resistance *R_r(t)* and *R_f(t)* respectively, in series with an ideal diode, as in other researches (Fuji 1994, 1991, IRC 1994, Chen 1995).

4. LOSSES

The value of the energy loss in the converter is an important measure not only for performance evaluation and optimization of the circuit design, but and an etalon of comparison amongst different active filters using different principles. The energy loss in this converter comprises of: i) switching losses, ii) conduction losses, iii) coil losses and iv) capacitor (dielectric) losses. This work emphasize with the switching and conduction losses and the influence of the snubber circuit on them.

4.1 Switching losses

The switching losses occur in the solid-state switches as the circuit makes its transition from one conduction state to the other. The average switching frequency of the two S₃ and S₄ switches of the

converter, Figures 1 and 2, is 25kHz as opposed to 50Hz for the two S₁ and S₂ switches. The losses in switches S₁ and S₂ are therefore ignored.

Like conduction losses (see below, section 4.2), "hard switching" operation is usually characterized by manufacturers in some ways: i) with tabular information in the data sheet, ii) with graphs in the data sheet or iii) with the switching model parameters for transistors. The switching energy reported in the data sheet makes specific reference to a test circuit that simulates a clamped inductive load operated with an ideal diode. Hence, it does not include the losses in the transistor when, in turning on, it carries the full load current, plus the reverse current of the freewheeling diode. And, supplementary and important for this study, is to know the influence of the snubber parameters (C_s, R_s) to the commutation transients and hence to the switching losses.

The method used to compute the switching losses in each bidirectional switch is described with the circuit of fig. 3 and using the dynamic turn-on and turn-off resistances.

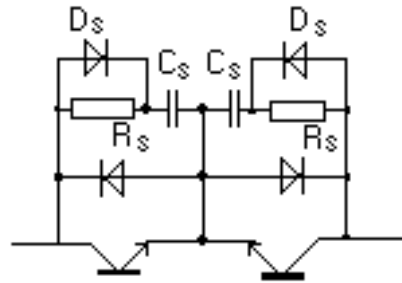

Fig. 3. A bidirectional switch from Fig. 2

The voltage across the solid-state switch is *v_{ss}* and the total current flowing by the switch is *i_{ss}*. The energy, *E_{in}*, supplied to each switch during one period *T* is partially used to supply the losses in the switch (*E_{loss}*), and partially stored in capacitances (*C_k*), and stray inductances (*L_k*), is:

$$(5) E_{in} = E_{loss} + \sum_k \frac{1}{2} C_k (V_{kf}^2 - V_{ki}^2) + \sum_k \frac{1}{2} L_k (I_{kf}^2 - I_{ki}^2)$$

where, *V_{kf}* and *V_{ki}* are the final and initial voltages respectively, across the capacitance *C_k*; *I_{kf}* and *I_{ki}* are the final and initial currents respectively, through the inductance *L_k*.

In steady state operation, the voltages and currents at the beginning and at the end of each cycle will be equal, and the switching losses will be computed with the expression:

$$(6) P_{loss} = \frac{E_{in}}{T} = \frac{1}{T} \int_0^T v_{ss} \cdot i_{ss} \cdot dt$$

During turn-on and turn-off processes, the transistors used in this work (Judele, 2001, Fuji 1994, Fuji 1991) were modeled by effective time varying resistances $R_r(t)$ and $R_f(t)$ respectively in series with an ideal diode.

The dynamic resistance v_{CE}/i_c , respectively the dynamic turn-on and turn-off resistances, $R_r(t)$ and $R_f(t)$, can be modeled by best fitting curves in each case from *measured* values and *from data sheet* (Figure 4).

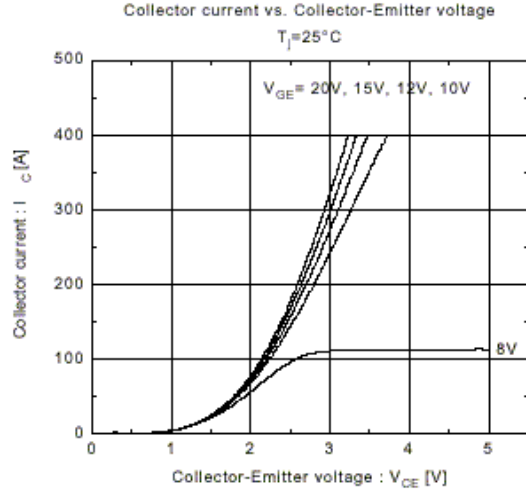

Fig. 4. The dependence of $V_{CE} - I_c$ on V_{GE} ($T_j = 25^\circ$)

The equations of these two best fitting curves used are, for turn-on:

$$(7) R_r(t) = a / t + b$$

and for turn-off:

$$(8) R_f(t) = d / (1 - t / t_f)$$

where t is actual time and t_f is total fall time, which is linear and strongly dependent of the on-state (collector) current value.

The time variations of R_r and R_f from (7) and (8) can be represented mathematically with the help of the four parameters a , b , d and t_f . Since $R_r(t = \infty) = b$ and $R_f(t = 0) = d$, results that $R_{on-state} = b = d$.

To predict the collector current waveforms during turn-on was used the data sheet values of v_{CE} and the model of R_r , and to predict the collector current

waveforms during turn-off was used the data sheet values and the model of R_f .

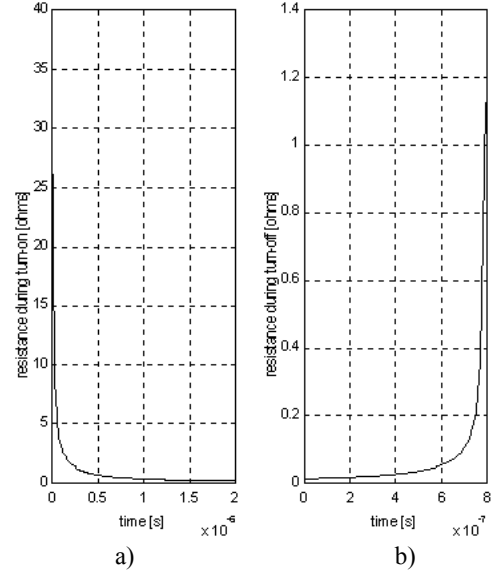

Fig. 5a. The dynamic resistance curve for transistor turn-on;

Fig. 5b. The dynamic resistance curve for transistor turn-off

For the turn-on and turn-off cases respectively, the switching energy loss predicted using the effective time varying resistance models of $R_r(t)$ and $R_f(t)$, Figure 5, was checked by comparing with the switching losses (E_{on} , E_{off}) vs collector current from the data sheet.

The percentage error demonstrates that these values are mostly within 5%, and the conclusion is that the model using the dynamically varying resistance model of $R_r(t)$ and $R_f(t)$ is capable of predicting the switching losses with an acceptable accuracy (see below, the section 5).

4.2 Conduction losses

The conduction losses are defined as the losses that occur between the end of the turn-on interval and the beginning of the turn-off interval, and occur when the voltage across the switch (IGBT or BJT) is less than 5% of the supply voltage.

Usually, at any given time, the energy dissipated in the transistors can be obtained with the following expression:

$$(9) E = \int_0^t V_{CE}(i) \cdot i(t) \cdot dt$$

where t is the length of the pulse. Power is obtained by multiplying energy by frequency. When the transistor is off, $i(t) \approx 0$, and losses are negligible. Unfortunately, no simple expression can be found for the voltage and current functions during a switching transient. Hence, is necessary to resort to a somewhat

Fig. 5
resista
transi

(artificial) distinction between conduction and switching losses (see above).

Usually, the *function* $V_{CE}(i)$ in the formula (9) expresses the conduction behavior of the transistors while the conduction losses are characterized by manufacturers in some ways: i) with tabular information in the data sheet; ii) with graphs in the data sheet and/or iii) with the conduction model parameters for transistors (IRC, 1994).

In the case of the converter, both the switching and conduction losses in each bidirectional switch are described and calculated with the help of Fig.3.

If the forward voltage drop across a solid-state switch is v_{ss} for a current i_{ss} , then the instantaneous power loss is given by

$$(10) \Delta P = v_{ss} \cdot i_{ss}$$

The variation of v_{ss} wrought i_{ss} for the transistors and diodes are obtained from the catalogue data provided by manufacturers. During either of the conduction model, Figure 2, two bidirectional switches are always conducting. Conduction through each bidirectional switch is through a transistor and a diode in series with it. If t_{ck} is the time of conduction during the k -th switching interval t_k , then the energy loss due to conduction in each bidirectional switch is given by

$$(11) \Delta e_{bsk} = v_{ss} \cdot i_{ss} \cdot t_{ck}$$

where v_{ss} is the sum of the voltage across the transistor and diode. Considering both switches during conduction, the total energy loss is

$$(12) \Delta E_k = 2 \cdot (\Delta e_{bsk}) = 2 \cdot v_{ss} \cdot i_{ss} \cdot t_{ck}$$

For a period T with a total of N switching intervals the energy loss due to conduction is

$$(13) \Delta P_{cond} = \frac{2}{T} \cdot \sum_{k=1}^N v_{ss} \cdot i_{ss} \cdot t_{ck}$$

5. SIMULATION RESULTS

The switching losses, commutation time, peak transistor voltage and peak transistors currents in the nodes 1 and 2 of commutation were computed using a program (Judele, 2001) where the transistors are modelled as dynamically varying resistances using finite difference equations. The dynamic resistances $R_f(t)$ and $R_r(t)$ were assumed to be constant for each discrete time step. The transistors chosen (IGBT) for the design of a single phase converter unit which generates 650kVAr at 6300V have voltage and current ratings of 1200V and 200A (1MBI200N-120, Fuji Electric, Fig. 4), and $a = 0,350 \mu\Omega s$, $t_f = 350ns$ for a collector current of 200A, $b = d = =v_{CE}/I_c =$

0.013Ω (computed from Fig.4 for the maximum allowable gate voltage). A total of 15 transistors were used for each bi-directional switch implementation for above converter unit. The snubber capacitance C_s was used as parameter in simulations to compute the energy losses.

- The switching losses, commutation time, peak transistor voltage and peak transistor current, all are dependent on $R_f(t)$ and $R_r(t)$, i.e. on the parameters a , d and t_f . The values of the energy losses per switching versus the angle at which the switching occurs are shown in Fig. 6a and b, for nodes 1 and 2 of commutation respectively. From these figures we see that the losses become smaller with smaller values of C_s (snubber capacitance). In the same time an observation is that the energy loss per switching in mode 2 of commutation is less than 1% that in mode 1, and therefore the mode 2 losses can be ignored.

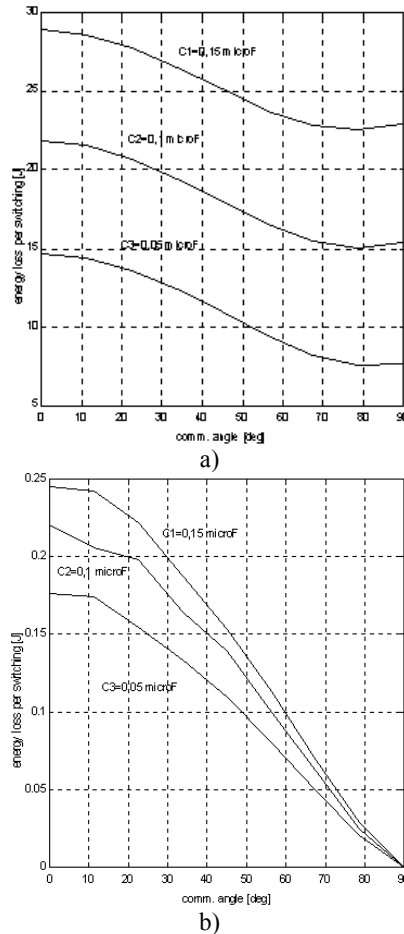

Fig. 6 Energy loss per switching in mode 1 (a) and in Mode 2 (b) of commutation versus the angle at which the switching occurs

- In fig. 7 is presented the variation of the commutation time in mode 1. We see again that the lower values of C_s are preferable. However, lower values of C_s mean higher values of peak transistor voltages during turn-off.

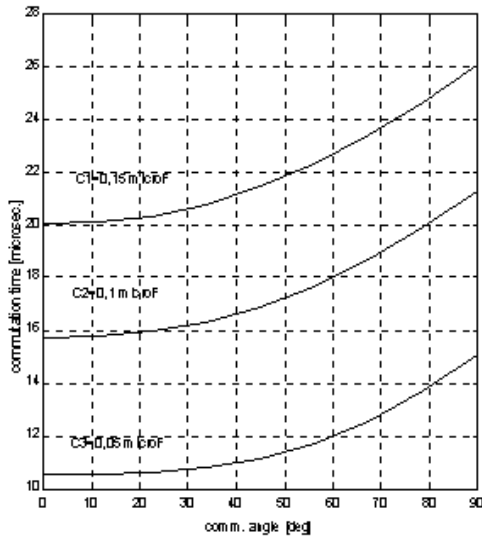

Fig. 7. Commutation time in mode 1 of commutation vs the angle at which the switching occurs

- Because the peak values of all the four transistor voltages v_i ($i = 1, 2, 3, 4$) were monitored, the peak voltage of the voltage v_1 , $v_{1 \max}$, was found to be largest. In Fig. 8 is presented the variation of $v_{1 \max}$ normalized to the maximum capacitor voltage $v_{c \max}$, $v_{1 \max}/v_{c \max}$. From this figure we see that if the maximum allowable value for $v_{1 \max}/v_{c \max}$ is chosen to be 2.5 or between (2 - 2.5), then the best choice of C_s will be 0,15 μF for this type of transistors. We recall that the allowable upper limit for $v_{1 \max}/v_{c \max}$ depends, however, on the degree of desired safety margin.

- The maximum transistor current, normalized to the peak value of the line current, is shown in Fig. 9

From this figure we see that for the peak transistor current also large values of C_s are preferred. Because the commutation time, Fig. 7, is much more less of the average conduction time of the transistors, the transistors can handle these current peaks, only of the order of the continuous current rating.

- The value of R_s is chosen thus that the time constant $R_s C_s = T_s$ is smaller than a third of the transistor conduction time. This is to be sure that during the transistor turn-on process, will be sufficient time available for the energy stored in the capacitance C_s to be completely dissipated.

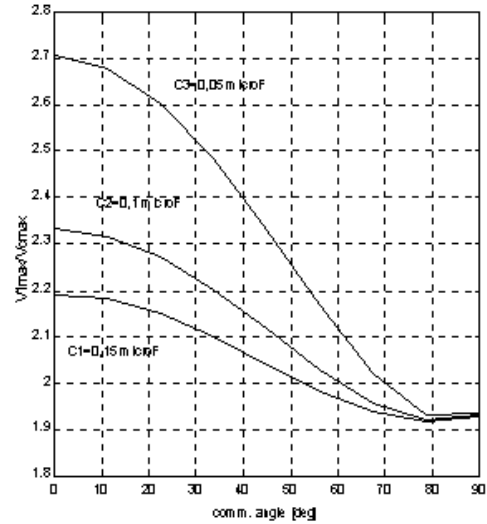

Fig. 8. The normalized $v_{1 \max}/v_{c \max}$ in mode 1 of commutation vs. the angle at which the switching occur

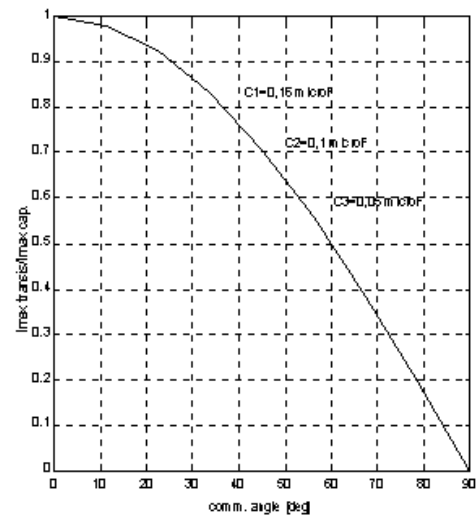

Fig. 9 The normalized maximum transistor current, $I_{\max \text{ transis}}/I_{\text{line}}$, vs. the angle at which the switching occurs

For example, if the switches S_3 and S_4 , Fig. 1, are operated with a switching frequency between (25 – 50) kHz, the conduction times can be considered to be between $\approx (20 - 10) \mu\text{s}$, i.e. the minimum conduction time is $\approx 10\mu\text{s}$.

In this (defavorable) case a choice of $R_s = 10\Omega$ guarantee that $3R_s C_s = 3\mu\text{s}$ is less than the minimum conduction time of the transistors ($10\mu\text{s}$).

6. CONCLUSIONS

The work is further on of the work (Judele *et al* 2001), and investigate some of the properties of this new power converter with switched capacitor, little known, but with a great potential to be used as reactive power controller, or as an active filter, and/or as an active power line conditioner.

Using dynamically varying resistance models for the converter transistors during turn-on and turn-off, in a more general context with difference equations for the conduction and commutation transients of the converter, were computed: the energy losses (switching, conduction), the commutation time, the maximum voltage and transistor current, each versus the angle at which the switching occurs, the influence of the snubber parameters of them.

The comparison of the energy losses obtained, by simulation with the losses of the transistors from the data sheet, shown that this approach have a good accuracy.

7. REFERENCES

- *** *Bipolar Power Module Catalog*, Fuji Electric, 1991.
- *** *Fuji IGBT Module Application Manual*, Fuji Electric, 1994.
- *** IEEE Special Stability Controls Working Group (1994). *Static VAR Compensator Models for Power Flow and Dynamic Performance Simulation*. IEEE Trans. on PS, Vol. 9, No. 1, pp. 229-240.
- *** *IGBT Designer's Manual*, Int. Rectifier Corp. El Segundo, CA, USA, 1994, TPAP-5, E-135.
- Abbott, K.M. and M.Davies (1995). *Modelling and Simulation of Static VAR Compensators for Control*. Proc. of. 6th European Conf. on. PE and Applic., EPE '95, Sevilla, Spain, pp. 2088-2093.
- Akagi, H. (1995). *New Trends in Active Filters*. 6th European Conf. On PE and Applic., Proc of EPE '95, Sevilla, Spain, pp. 0.017-0.026.
- Chakravorti, A.K. (1992). *The Design, Performances and Energy Flow Phenomenon in Active Filter and Active Power Line Conditioner Using a Switched Capacitor Static Volt*. Diss., Worcester Polytechnic Institute, USA.
- Chen, K. et al. (1995). *Soft Switching Active Snubber Optimized for IGBT's in Single Switch Units Power Factors Three-Phase Diode Rectifiers*. IEEE Trans. on PS., Vol. 10, No. 4, pp. 446-452.
- Dugan, V., Z. Vasiliu and S.Judele (1997). *Simulation of Two Active Power Filter Topologies to Cancel Neutral Current Harmonics in Low Voltage Electric Power Distribution*. Proc. of. the Int. Conf. on Microelectronics and Computer Science, ICMCS '97, Chishinew, Republic of Moldavia, pp. 234-240.
- Judele, S. (2001). *Modelarea si simularea unui convertor static cu capacitate comutata, utilizat ca filtru activ si conditioner de putere activa*. Referat de doctorat, nr. 3, U.Galati.
- Judele, S., R. Solea, and V. Dugan (2001), *Limitations of a Static VAR Compensator (SVC) with Switched Capacitor Operating as an Active Filter*, The "Annals of "Dunarea de Jos" University of Galati", Fasc. III (EEAI), 2001, 19-28.
- Mohan, N., T.M. Undeland and W.P. Robbins (1995). *Power Electronics. Converters. Applications and Design*. Wiley, 2e, NY, USA.